

# ***Instruction Guide***

***for***

***All-American 8™ Turret Press***

***Victory™ Single Stage Press***

***Ideal™ C-Frame Press***

***BrassSmith™ Powder Measure***



# *All-American 8™ Turret Press*



# Brass Smith All-American 8 Reloading Press

## Overview

Congratulations on your purchase of the Lyman All- American 8 Reloading Press. Please read over all instructions prior to use.

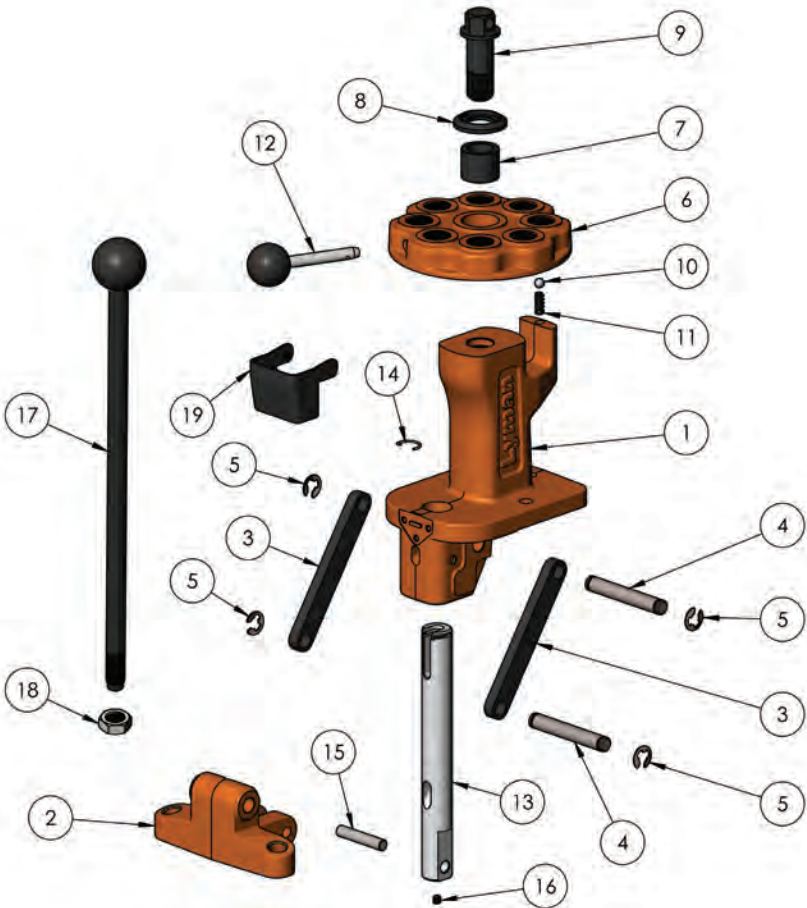

- |    |                          |          |    |                               |         |
|----|--------------------------|----------|----|-------------------------------|---------|
| 1  | Body .....               | 7990510  | 11 | Turret Ball Detent Spring ... | 2990738 |
| 2  | Toggle .....             | 7726225  | 12 | Turret Handle .....           | 7991465 |
| 3  | Link, Straight .....     | 7991470  | 13 | Ram .....                     | 7726230 |
| 4  | Link Pin.....            | 7726215  | 14 | Shell-Holder Clip .....       | 7726109 |
| 5  | Link Pin Clip.....       | 7726220P | 15 | Ram Pin.....                  | 7726232 |
| 6  | Turret.....              | 7726160  | 16 | Set Screw.....                | 7726464 |
| 7  | Turret Bushing .....     | 7991452  | 17 | Handle.....                   | 7726114 |
| 8  | Turret Bolt Washer ..... | 7991451  | 18 | Handle Jam Nut.....           | 7726218 |
| 9  | Turret Bolt.....         | 7991450  | 19 | Primer Catcher .....          | 7726219 |
| 10 | Turret Ball Detent ..... | 2990730  |    |                               |         |

## Unpacking and Assembly

1. Remove press from packaging, ensure all parts are present.

- Assembled All- American 8 Press (1)
- Handle with knob and jam nut (1)
- Primer Catcher (1)
- Primer Feed body (1)
- 10-32 mounting screws (3)
- Large Brass Primer Tuber with Cotter Pin (1)
- Small Brass Primer Tube with Cotter Pin (1)
- Small Primer Sleeve/Punch with spring.

This is installed in primer feed body from the factory

- Large Primer Sleeve/Punch with spring (1)
  - Steel Blast Shield (1)
  - 5/32nd Hex wrench (1)
  - 1/16th Hex Wrench (1)
  - Instruction Manual (1)
  - Turret Handle (1)
2. Place press on reloading bench or other flat surface to make assembly easier.
3. Thread handle in toggle and tighten jam nut.

## Press set up and use

1. Bolt press firmly to bench.
2. Insert shell holder into the slot at the top of the ram. It will snap into place.
3. Die set up; Follow your die manufacturers set up instructions for your particular die set.
4. To remove turret use a 7/8th socket or insert a screwdriver through hole in turret bolt.

## Straight Line Primer Feed set up Instructions

1. Locate Primer Feed Body and three mounting screws. (photo 1)
2. The primer feed body comes with the small primer punch installed at the factory. If you wish to install the large primer punch prior to mounting the primer feed body to the press, you have to unthread the knurled knob, remove spring and pull the priming arm out of housing. Loosen the small set screw at the bottom of the punch and remove small primer punch and install the large primer punch.



3. Reinstall arm through the primer feed body, slide on spring and thread on knurled knob.
4. Place primer feed onto the press body and install the three mounting screws.
5. To load primers into the large or small brass primer tubes follow these steps; all primers to be loaded into tube must be positioned with the anvil side down and smooth side up.
6. Making sure the cotter pin is installed into the brass primer tube. Take the split end of the primer tube and place it over a primer and gently push down, the primer will snap into the tube

and hold there. Continue to press primers into the tube until full, approximately 50 primers.

7. Place the silver collared end of the tube into the primer feed body and press firmly into housing to seat tube. (photo 2)
8. Remove cotter pin and primers will be ready to feed. Place blast shield over brass tube and seat into primer feed body. (photo 3)
9. Place spent primer catcher onto press (photo 4)



### Using the Straight Line Primer Feed

1. Before you can prime the first case, you will need to load a primer into the primer punch/cup. Pull back on the knurled knob approximately 3/16ths of an inch, this will drop a primer into the cup.
2. Lower the press ram until the slot in the ram (just below the shell holder) is directly in front of the priming arm. Push the priming arm forward and into the slot. Hold it in this position.
3. Push handle up to lower the ram and seat the primer, then release priming arm and remove primed shell.
4. You will need to pull the knurled knob back approximately 3/16ths of an inch each time in order to drop a primer into the primer punch/cup.



NOTE: The priming arm can be used either with the spring assist or without it.

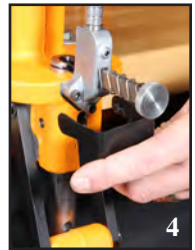

### Maintenance and Troubleshooting

Your Lyman All-American 8 Press has been designed to give you years of trouble free service, but some preventive maintenance is required.

Before using your press, apply a light film of powdered graphite to the bearing surfaces of all moving parts. Pay particular attention to the sides of the ram. Thin oil can also be used for this purpose but powdered graphite is recommended.

To clean your press, use a lightly dampened cloth and wipe the press free of dirt, and contamination from the press after every use.

Check tightness of turret bolt prior to starting a reloading session, and periodically check during the reloading session.

### Trouble Shooting

Here are some simple troubleshooting tips.

#### Shell holder loose or falling out.

Make sure shell holder clip is installed on ram.

Handle loose

Make sure handle is threaded completely into toggle and silver jam nut is tight against toggle.

#### Sticky or Tight Ram

Make sure ram is free of dirt. Use damp cloth to wipe ram, then dry ram and add a thin film of powdered graphite to the ram.

Inspect ram to insure no spent primers are jammed between ram and press body or linkage.

Remove any spent primers from linkage.

# ***Victory™ Single Stage Press***



# Brass Smith Victory Reloading Press

## Overview

Congratulations on your purchase of the Lyman Victory Reloading Press. Please read over all instructions prior to use.

## Parts Diagram

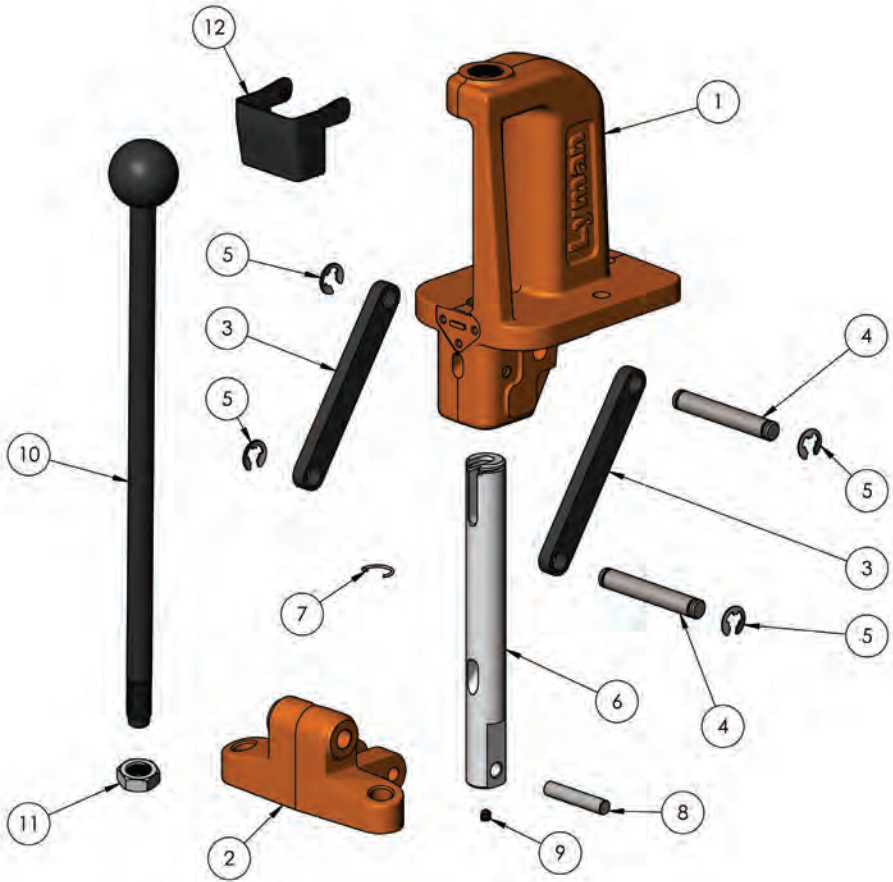

1	Body .....	7726200	7	Shell-Holder Clip .....	7726109
2	Toggle .....	7726225	8	Ram Pin.....	7726232
3	Link, Straight .....	7991470	9	Set Screw.....	7726464
4	Link Pin.....	7726215	10	Handle.....	7726114
5	Link Pin Clip.....	7726220P	11	Handle Jam Nut.....	7726218
6	Ram.....	7726230	12	Primer Catcher .....	7726219

## Unpacking and Assembly

1. Remove press from packaging, ensure all parts are present.

- Assembled Victory Press (1)
- Handle with knob and jam nut (1)
- Primer Catcher (1)
- Primer Feed body (1)
- 10-32 mounting screws (3)
- Large Brass Primer Tube with Cotter Pin (1)
- Small Brass Primer Tube with Cotter Pin (1)
- Steel Blast Shield (1)
- Small Primer Sleeve/Punch with spring.  
This is installed in primer feed body from the factory (1)
- Large Primer Sleeve/Punch with spring (1)
- 5/32nd Hex wrench (1)
- 1/16th Hex Wrench (1)
- Instruction Manual (1)

2. Place press on reloading bench or other flat surface to make assembly easier.

3. Thread handle in toggle and tighten jam nut.

## Press set up and use

1. Bolt press firmly to bench.
2. Insert shell holder into the slot at the top of the ram. It will snap into place.
3. Die set up; Follow your die manufacturers set up instructions for your particular die set.

## Straight Line Primer Feed set up Instructions

1. Locate Primer Feed Body and three mounting screws. (photo 1)

2. The primer feed body comes with the small primer punch installed at the factory. If you wish to install the large primer punch prior to mounting the primer feed body to the press, you have to unthread the knurled knob, remove spring and pull the priming arm out of housing. Loosen the small set screw at the bottom of the punch and remove small primer punch and install the large primer punch.

3. Reinstall arm through the primer feed body, slide on spring and thread on knurled knob.

4. Place primer feed onto the press body and install the three mounting screws.

5. To load primers into the large or small brass primer tubes follow these steps; all primers to be loaded into tube must be positioned with the anvil side down and smooth side up.

6. Making sure the cotter pin is installed into the brass primer tube. Take the split end of the primer tube and place it over a primer and gently push down, the primer will snap into the tube and hold there. Continue to press primers into the tube until full, approximately 50 primers.





7. Place the silver collared end of the tube into the primer feed body and press firmly into housing to seat tube. (photo 2)
8. Remove cotter pin and primers will be ready to feed. Place blast shield over brass tube and seat into primer feed body. (photo 3)
9. Place spent primer catcher onto press (photo 4)



### Using the Straight Line Primer Feed

1. Before you can prime the first case, you will need to load a primer into the primer punch/cup. Pull back on the knurled knob approximately 3/16ths of an inch, this will drop a primer into the cup.
2. Lower the press ram until the slot in the ram (just below the shell holder) is directly in front of the priming arm. Push the priming arm forward and into the slot. Hold it in this position.
3. Push the press handle forward to lower the ram and seat the primer, then raise the ram slightly and release the priming arm. Remove primed shell.
4. You will need to pull the knurled knob back approximately 3/16ths of an inch each time in order to drop a primer into the primer punch/cup.



NOTE: The priming arm can be used either with the spring assist or without it.

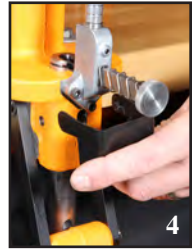

### Maintenance and Troubleshooting

Your Lyman Victory Press has been designed to give you years of trouble free service, but some preventive maintenance is required.

Before using your press, apply a light film of powdered graphite to the bearing surfaces of all moving parts. Pay particular attention to the sides of the ram. Thin oil can also be used for this purpose but powdered graphite is recommended.

To clean your press, use a lightly dampened cloth and wipe the press free of dirt, and contamination from the press after every use.

### Trouble Shooting

Here are some simple troubleshooting tips.

#### Shell holder loose or falling out.

Make sure shell holder clip is installed on ram.

#### Handle loose

Make sure handle is threaded completely into toggle and silver jam nut is tight against toggle.

#### Sticky or Tight Ram

Make sure ram is free of dirt. Use damp cloth to wipe ram, then dry ram and add a thin film of powdered graphite to the ram.

Inspect ram to insure no spent primers are jammed between ram and press body or linkage.

Remove any spent primers from linkage.

# Brass Smith Primer Feed

## Parts Diagram

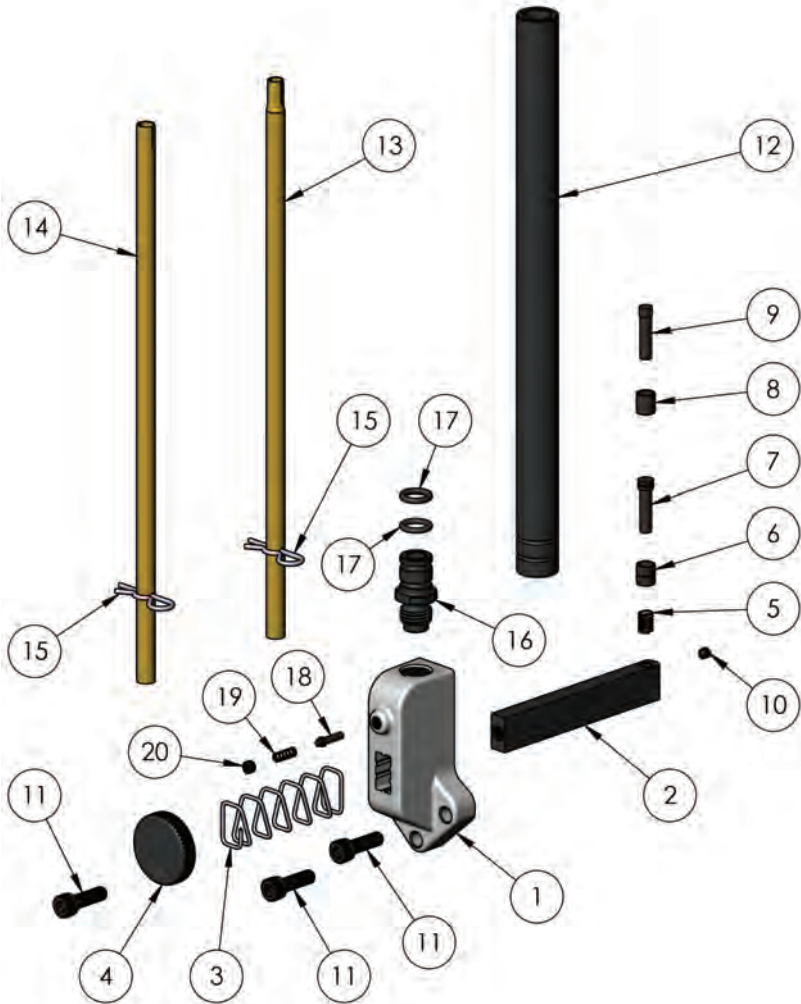

- 1 Primer Feed Body . . . . . 7726135
- 2 Primer Feed Arm. . . . . 7726139
- 3 Arm Return Spring . . . . . 7726141
- 4 Arm Push Knob. . . . . 7726140
- 5 Punch Sleeve Spring. . . . . 7992920
- 6 Large Punch Sleeve. . . . . 7992918
- 7 Large Primer Punch . . . . . 7726130
- 8 Small Punch Sleeve. . . . . 7992919
- 9 Small Primer Punch . . . . . 7726131
- 10 Punch Set Screw . . . . . 7726148

- 11 Mounting Screw . . . . . 7726147
- 12 Blast Shield. . . . . 7726138
- 13 Primer Tube, Small . . . . . 7726142
- 14 Primer Tube, Large . . . . . 7726143
- 15 Primer Tube Clip. . . . . 7726144
- 16 Blast Shield Adapter. . . . . 7726136
- 17 Adapter O-Ring. . . . . 7726137
- 18 Primer Stop Plunger . . . . . 7726146
- 19 Plunger Spring. . . . . 7726145
- 20 Plunger Set-Screw. . . . . 7994418

# *Ideal™ C-Frame Press*



# Brass Smith Ideal Reloading Press

## Overview

Congratulations on your purchase of the Lyman Ideal Reloading Press. Please read over all instructions prior to use.

## Parts Diagram

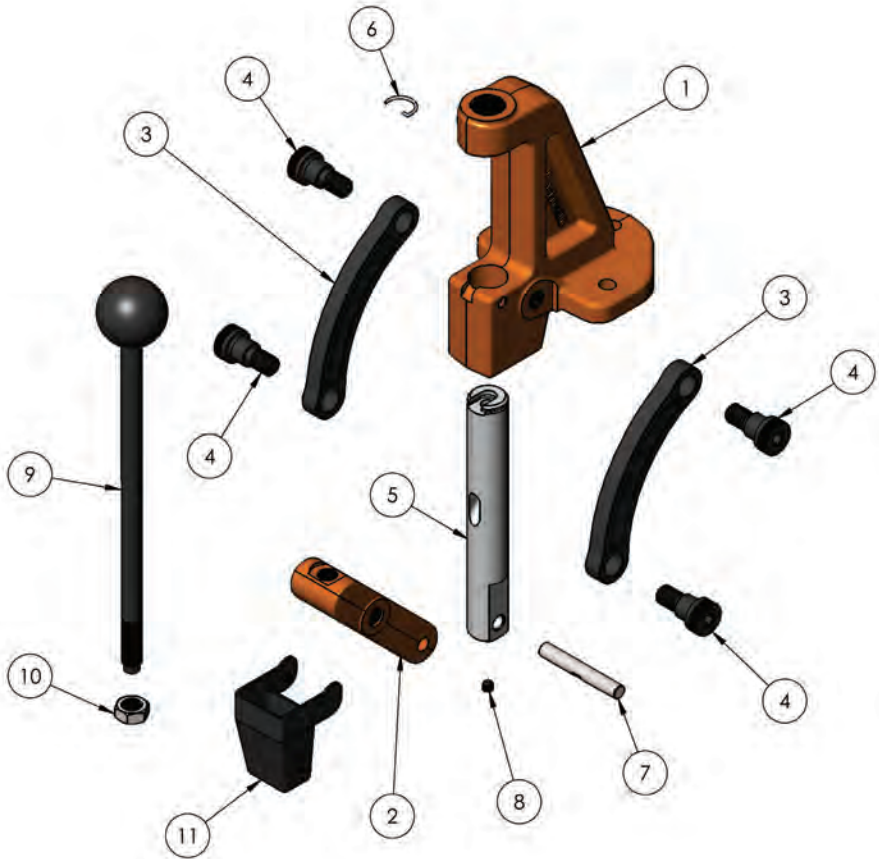

1	Body .....	7726450	7	Ram Pin.....	7726462
2	Toggle .....	7726452	8	Set Screw.....	7726464
3	Link, Curved .....	7726454	9	Handle.....	7726461
4	Shoulder Screw .....	7726456	10	Handle Jam Nut.....	7726466
5	Ram .....	7726458	11	Primer Catcher .....	7726468
6	Shell-Holder Clip .....	7726109			

## Unpacking and Assembly

1. Remove press from packaging, ensure all parts are present;
  - Press body (1)
  - Ram, toggle, linkage assembly (1)
  - Shoulder bolts (4)
  - Handle (1)
  - Spent Primer Cup (1)
  - 5/16ths Hex Wrench (1)
  - Instruction manual (1)
  - Packet of Thread Lock (1)
2. Place press body on reloading bench or other flat surface to make assembly easier.
3. Insert ram through bottom of press body. (photo 1)
4. Place a small drop of the supplied thread lock onto the two shoulder bolt threads. Insert top two shoulder bolts through links and thread into mounting holes on the press body. NOTE: You will need to hold the ram in place until at least one shoulder bolt is fully installed. Tighten shoulder bolts until snug. (photo 2)
5. Thread handle into toggle and tighten jam nut. (photo 3)
6. Place primer catcher onto press. (photo 4)

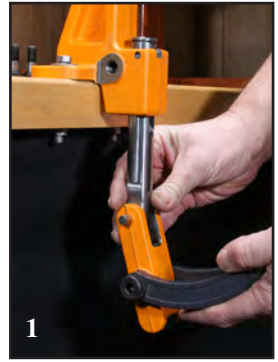

## Set Up and Use

1. Bolt press firmly to bench. The press body can be used as a template for the bolt pattern and spacing.
  2. Insert shell holder into ram
  3. Die set up; Follow your die manufactures set up instructions for your particular die or die set.
- Your Lyman Ideal Reloading Press is now ready for use.

## Maintenance and Trouble Shooting

Before using your press, apply a light film of powdered graphite to the bearing surfaces of all moving parts. Pay particular attention to the sides of the ram. Thin oil can also be used for this purpose but powdered graphite is recommended.

To clean your press, use a lightly dampened cloth and wipe the press free of dirt, and contamination from the press after every use.

## **Trouble Shooting**

Your Lyman Ideal Press has been designed for years of trouble free use. Here are some simple troubleshooting tips.

### **Shell holder loose or falling out.**

Make sure shell holder clip is installed on ram.

### **Handle loose.**

Make sure handle is threaded completely into toggle and silver jam nut is tight against toggle.

### **Sticky or Tight Ram**

Make sure ram is free of dirt. Use damp cloth to wipe ram, then dry ram and add a thin film of powdered graphite to the ram.

Inspect ram to insure no spent primers are jammed between ram and press body or linkage.

Remove any spent primers from linkage.

### **Excessive side to side play on handle;**

Inspect and re-tighten any of the four shoulder bolts on linkage. Tighten shoulder bolts snugly, if problem continues add a small amount of blue (non-permanent) thread locker to the shoulder bolt threads and tighten shoulder bolts.

# ***Brass Smith™ Powder Measure***



# Brass Smith Powder Measure

## Overview

Lyman's Brass Smith Powder Measure is unmatched for value, features and performance! Whether dropping charges for small pistol cases or large rifle cases, this measure gives consistent and accurate performance. The CNC machined steel metering cylinder features a micrometer adjustable thimble with reference lines so resetting the measure is easy. The reservoir is equipped with a powder baffle which maintains a consistent powder level for top accuracy. The cylinder also allows for the handle to be positioned on either side for true ambidextrous use, plus it can be positioned at different angles for maximum user comfort. The measure body is machine with a 7/8"x14 thread to fit all standard presses and stands. It also includes two drop tubes to cover the full range of calibers.



1 Body .....	7767720	11 Rotor Arm Screws.....	7994387
2 Rotor .....	7767721	12 Drop Tube Adapter .....	7767729
3 Meter Tube .....	7767722	13 Hex Lock Ring with Set Screw	7990119P
4 Plunger O-Ring.....	7767732	14 Drop Tube Lock Screw.....	7767728
5 Plunger .....	7767724	15 Case Adapter, Large .....	7767731
6 Meter Knob.....	7767723	16 Case Adapter, Small .....	7767730
7 Coarse Adjustment Lock Screw .	7767733	17 Reservoir cap.....	7990294
8 Rotor Arm .....	7767725	18 Reservoir Tube .....	7998298P
9 Handle Screw .....	7767726	19 Powder Baffle .....	7990263
10 Handle Knob.....	7767727		



## Clean the Measure

After unpacking the Brass Smith Powder Measure, the entire unit should be thoroughly cleaned to remove any oil or preservatives that cause powder to stick. We recommend the use of alcohol on patches or soft cloths. It is recommended to disassembling the metering cylinder by loosening the brass thumb screw and removing the outer knurled sleeve by unthreading it fully. Next pull the center plunger out of the unit. This will allow access to the inside of the metering cylinder. A patch on a cleaning rod would work well to clean inside this cylinder. Reassemble the metering cylinder by pushing the plunger back up inside the cylinder and position the flat side with reference lines facing up. Then screw the knurled sleeve back onto the metering cylinder. Gently try to rotate the metering cylinder. If it does not turn easily, the plunger is in too deep. Pull it downwards slightly to correct this.

## Setting up the Measure

Attach the handle to the powder drum with the two supplied screws. Note that the handle can be positioned for either right or left hand operation, as well as at several different angles. Most users will find that positioning the handle so that it is in line with the metering cylinder will provide the most comfortable operation. Next, select the drop tube adapter for the caliber that you are loading. Two are supplied, one small and one large. The small adapter will work with 204 to 25 caliber cases. Above that, use the large adapter. Thread it into the bottom of the 7/8"x14 drop tube and thread the drop tube into your press or powder measure stand. Place the body of the measure onto the drop tube and lock it in place with the large thumb screw. Note that there are dimples around the outside of the drop. Make sure that the thumb screw enters one of the dimples when it is tightened.

**Warning: This powder measure is NOT designed or recommended for use with black powder. Only smokeless powder should be used!**

## Setting the Charge Weight

The measure can be adjusted for charges of approximately 1.0 grains up to around 130 grains. To adjust the metering cylinder for most pistol loads, make sure the brass thumb screw is tight and slowly unthread the outer sleeve. Drop charges at various points and check them on a scale. Adjust the sleeve in or out as needed to bring your charge to the desired weight. For rifle charges, the center plunger will need to be pulled downwards in the metering cylinder. Note that there are reference lines on the plunger. Loosen the brass thumb screw and pull the plunger down one line at a time, then re-tighten the thumb screw. Drop charges and check them on a scale. Fine tune the charge weight by threading the outer sleeve in and out. If the proper charge weight cannot be reached by adjusting the outer sleeve, loosen the thumb screw and pull the plunger down another line. Then re-tighten the thumb screw. Please note that the plunger is only a coarse adjustment. All fine tuning of your charges will be done with the outer sleeve. Always verify charges with a scale after making any adjustments! We recommend dropping and weighing 10 charges to verify the proper charge weight is being dropped before loading cases.

## Charging the Shell

Once your charge weight is set, place a case against the funnel mouth of the drop tube adapter and work the handle of the measure. Note that the charge drops when the handle is in the up position. When working the handle, it is important to move the handle fully up and down so that the metering cylinder makes firm contact with its stop points. Do not short stroke the handle! Making contact with the stop points each time will produce consistent powder drops.

## Notes on Powder Measure Usage

All powder measures are of a basic design and the operator must acquire the knack of using one for best results. You will notice that fine-grained powders will measure easily and accurately, while coarse grained powders can be more difficult to drop accurately. This is because the coarse grain powder will often get caught between the edge of the metering cylinder and the measure's body, and will cause considerable resistance as the granules are cut. Remember, the handle must be moved uniformly and consistently each time to achieve accurate charges. **WARNING:** Use caution when dropping charges of stick powder with the small drop tube adapter as it is possible for powder to "bridge" and cause some of the charge to remain in the tube. This could produce a squib load. Also, if another charge is then dropped, the powder that remained in the tube, as well as the additional charge may all go into the case causing an overcharge.

**VISIBLY VERIFY THAT ALL CHARGES ARE THE SAME HEIGHT IN THE CASES BEFORE SEATING BULLETS!**

## LYMAN PRODUCTS WARRANTY

This warranty covers all products manufactured and supplied by Lyman Products as well as all its associated brands. Your Lyman Product has been produced under rigid standards of manufacture and inspection and are warranted against material defects and workmanship.

Products which are manufactured by Lyman Products are covered by a LIMITED LIFETIME WARRANTY. This warranty is extended only to the original consumer purchaser. All Lyman products are intended for non-commercial use by hobbyists. Any other use of these products will void the warranty. Should you believe that your product is defective in material or workmanship you must return the product to Lyman Products Corporation postage paid for evaluation. (See Return Policy) If the returning defective product meets the criteria of this warranty the product will be repaired or replaced at Lyman Products' option at no charge, parts and labor are included.

Lyman reloading tools and accessories are warranted against defective materials and workmanship only. This warranty is void if the product:

- (1) has been damaged by accident or unreasonable use, neglect, improper service or other causes not arising out of defects in material or workmanship;
- (2) has been altered or repairs have been made or attempted by someone other than authorized factory personnel
- (3) is used commercially
- (4) has been altered or defaced in any way.

THE LIMITED LIFETIME WARRANTY DOES NOT COVER DEFECTS OR DAMAGE RESULTING FROM: COMMERCIAL USE, ABUSE, IMPROPER INSTALLATION, MODIFICATION, LACK OF CARE, MISUSE OR NORMAL WEAR AND TEAR. THE IMPLIED WARRANTIES OF MERCHANTABILITY AND FITNESS FOR A PARTICULAR PURPOSE ARE LIMITED TO THE DURATION OF THIS LIMITED LIFETIME WARRANTY. LYMAN PRODUCTS CORPORATION IS NOT LIABLE FOR DAMAGES IN EXCESS OF THE PURCHASE PRICE OF THE PRODUCT AND UNDER NO CIRCUMSTANCES SHALL LYMAN PRODUCTS CORPORATION BE LIABLE FOR CONSEQUENTIAL OR INCIDENTAL DAMAGES. HOWEVER, SOME STATES DO NOT ALLOW LIMITATIONS ON INCIDENTAL, OR CONSEQUENTIAL DAMAGES, SO THE ABOVE LIMITATION OR EXCLUSION MAY NOT APPLY TO YOU.

This warranty gives you specific legal rights, and you may also have other rights which vary from state to state. Lyman Products is proud of our workmanship and quality that we build into our products. While our products are warranted against defective materials and workmanship we cannot warranty;

- Product sales to government or local law enforcement institutions or agencies
- Rust or corrosion
- Obstructions in barrels
- Finishes or Slides
- Sales of the product to second or subsequent owners
- Items purchased second hand
- Ammunition

Lyman Products will replace any missing hardware free of charge even if you lose it. Lyman Products is so confident you will be happy with your purchase that if for any reason you are not we will take back the product for a full refund within 30 calendar days of your original purchase. Receipt must be provided. Please contact Customer Service at 800-225-9626.

At Lyman, customer satisfaction and quality are our top priorities. If you are experiencing any problem with this product,  
**DO NOT RETURN IT TO YOUR RETAILER.**

Please, let us help.

If the item has a missing part, is damaged, or if you need help with the instructions, call us toll-free at 1-800-22-LYMAN(59626) Monday - Friday 9:00 AM to 4:15 PM (EST) or go to our website at [www.lymanproducts.com](http://www.lymanproducts.com) and click on the Contact tab at the top and select "Contact Us".

Also for your information, product instructions, part numbers, and videos on many of our products are listed on our website.

**[www.lymanproducts.com](http://www.lymanproducts.com)**

Thank you for your business!

# **Lyman<sup>®</sup>**

**Lyman Products Corporation  
475 Smith Street  
Middletown CT 06457  
1 800 225-9626  
860 632-2020  
Fax 860 632-1699**